

CAD FILE:

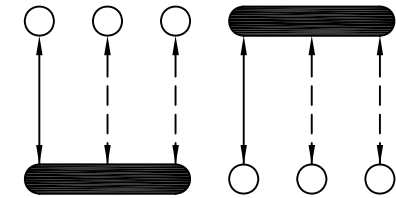

SCHMATIC (SHORTING)

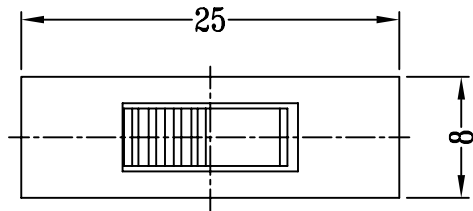
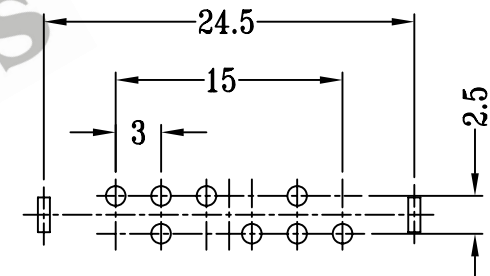
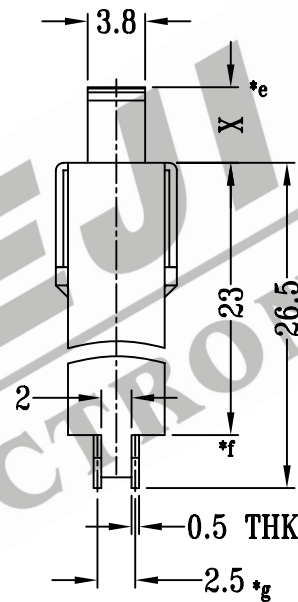
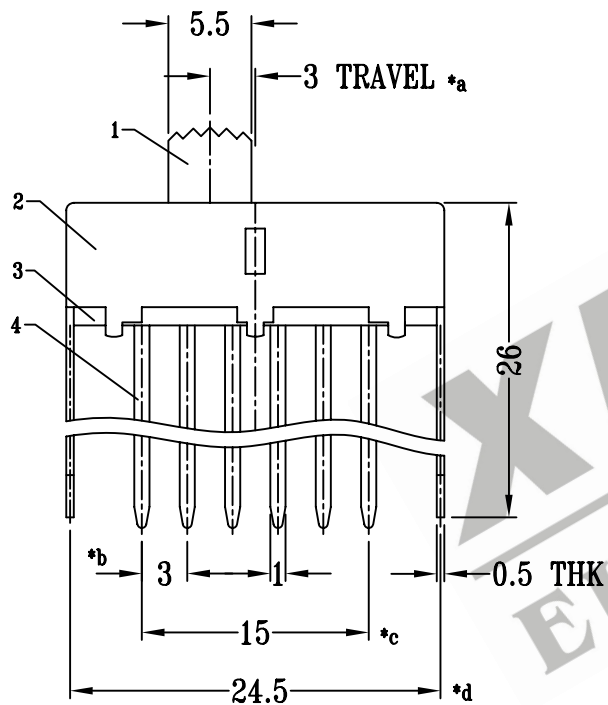

P.C.B LAYOUT

注:带"*"表示关键尺寸(7个)

NO.	PARTS	MATERIALS	Q'TY	FINISH	TOLERANCE UNLESS SPECIFIED	SHENZHEN XIEJIA ELECTRONICS CO.,LTD.				
8						TITLE : VERTICAL SLIDE SWITCH				
7	STEEL BALL	STEEL	2	NATURAL						UNIT : mm
6	SPRING	STEEL WIRE	3	TEMPER	WITHIN : 1.5±0.1mm OVER : 1.5±0.2mm	DRWG NO.: XJ-DR-SS23F25-00				
5	CONTACT CLIP	BRASS STRIP	2	Ag PLATED						ISSUE
4	TERMINAL	BRASS STRIP	8	Ag PLATED OVER Ni PLATED		SCALE: 2:1				
3	BASE	PHENOLIC RESIN	1	BLACK						DWN. ZHOUYU 2005-9-18
2	FRAME	STEEL STRIP	1	Ni PLATED		CHK'D FANGYING 2005-9-18				
1	KNOB	POM	1	BLACK						APPD. KANGXINAN 2005-9-18
					ALL MATERIALS MUST BE COMPLIANT TO ROHS					